

# INSTRUCTIONS FOR THE USE OF YOUR EMSEAL LAMINATOR



P: 07 3352 4222 | F: 07 3352 4333

E: [sales@qld.directnational.com.au](mailto:sales@qld.directnational.com.au)

[www.directnational.com.au](http://www.directnational.com.au)

**THIS MANUAL COVERS THE  
FOLLOWING MODELS:**

**Compact  
Emseal  
Centaur  
2R Applikator  
4R Applikator  
Triseal  
Makrolam**



**EMSeal**

# CONGRATULATIONS

You have just received your new Emseal laminator. No doubt you are now consumed with an overwhelming desire to rip open the packaging, set up the machine, and get to work. All we ask is that you FIGHT THE URGE! Make a cup of coffee, find a quiet corner, and then...

## READ THIS FIRST!!

This Laminator is designed to give high quality results using either self adhesive or thermal films, depending on model purchased. Of course, to obtain a consistently good result, you must first understand a little about the machine.

The purposes of this manual are to:

- 1) Describe how to operate the machine and give you an understanding of the processes involved in laminating and mounting.
- 2) Know what to do when things go wrong.
- 3) To stop you voiding the warranty we give.

---

# INDEX

---

	Page No.
1. Mobile Trolley Stand	1
2. Positioning your Laminator	2
3. Theory - How a thermal laminator works	3
4. Theory - How a pressure sensitive Laminator works	4
5. Unpacking/assembling your Laminator	5
6. Loading film	9
7. 2R Applikator roller opening system	16
8. Triseal 4R Applikator roller opening system	17
9. Adding/removing Triseal heater bar	18
10. Feeding items into your Laminator	19
11. Board Mounting	21
12. Tips and tricks	23
13. Troubleshooting	24

# MOBILE LAMINATOR STAND

## assembly guide

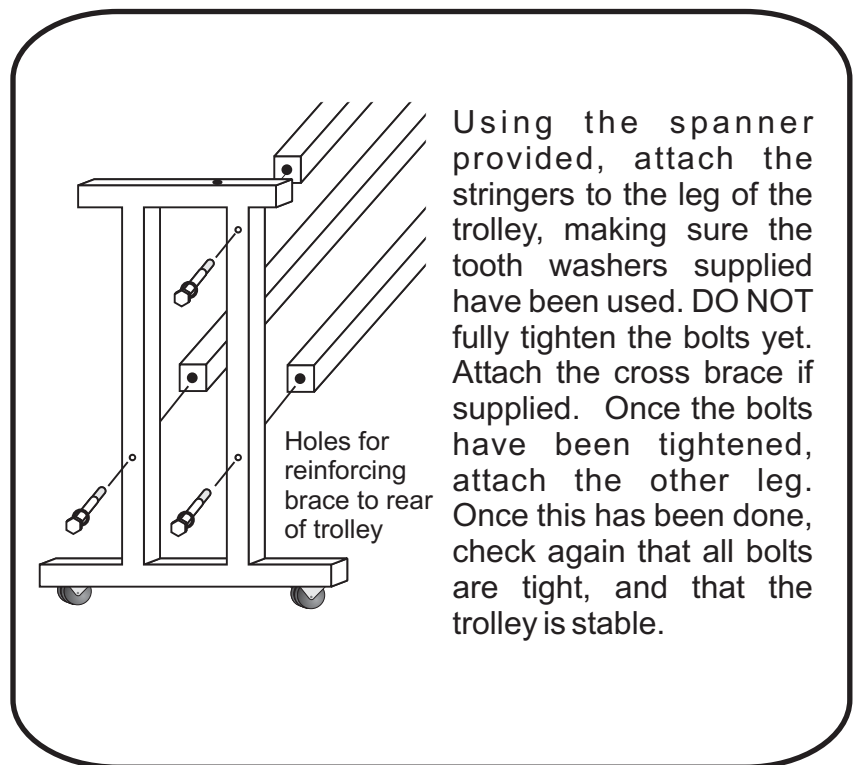
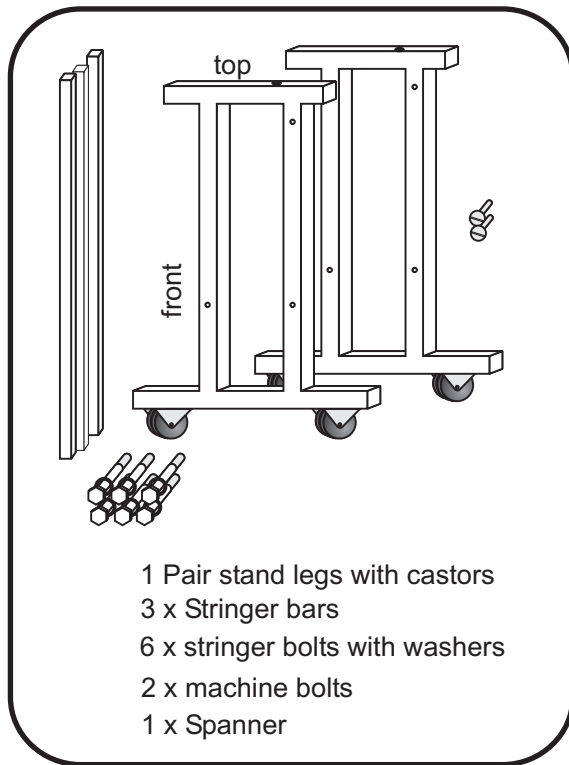

### Fixing your laminator to the stand

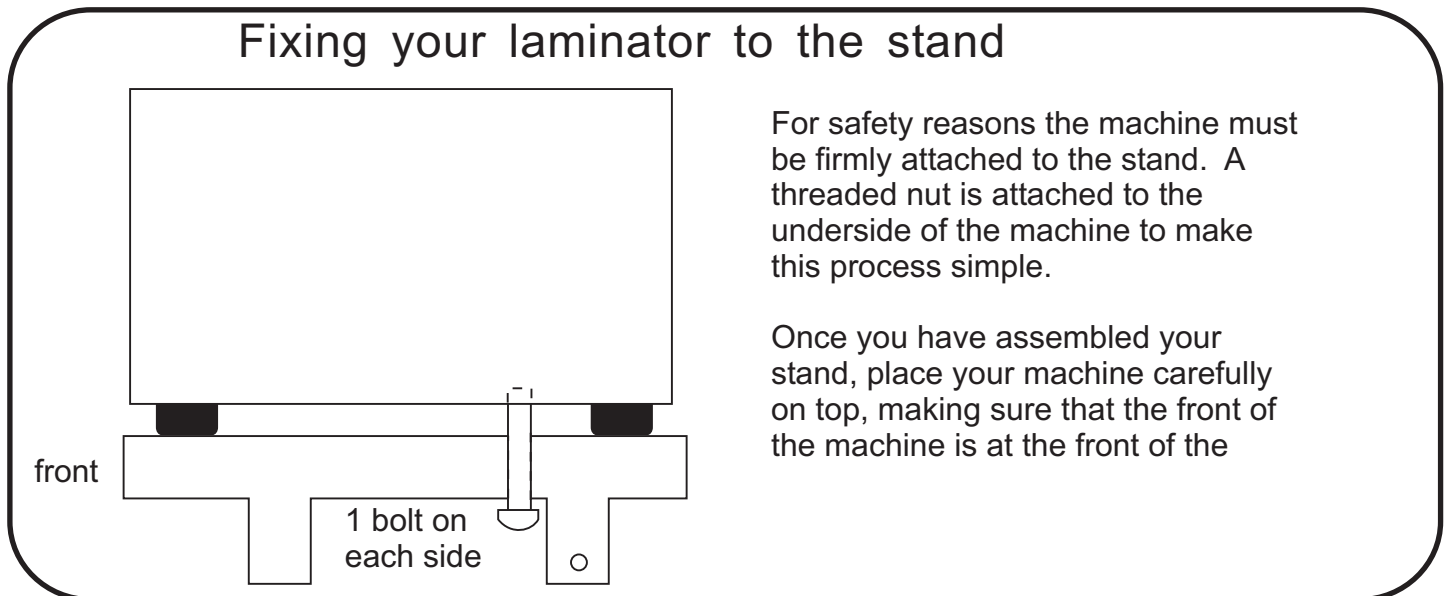

You have now successfully assembled your stand and positioned your laminator.

### SAFETY TIPS

Please remember to lock the front castors of the trolley whenever the machine is not being moved.

When moving the machine, move it slowly and evenly.

This trolley is designed for use on indoor and smooth surfaces, such as carpet, linoleum and concrete. It is not designed for transporting the machine over rough surfaces, as this may cause damage to the castors, and possibly to the laminator as well.

# POSITIONING YOUR LAMINATOR

Remove the foam packing from around the machine, and with someone else assisting you, lift the machine onto the work stand. No attempt should be made to lift the laminator by the chrome idler bars as this will result in damage. Remember when lifting to bend your knees and keep your back straight to prevent over stressing and possible damage to your back.

Remove the plastic wrapping from around the machine.

Ensure that your Laminator is bolted firmly to the specially designed mobile stand (If ordered). The mobile stand is not designed to be used on rough surfaces, and should be moved with care.

Some pressure sensitive and Thermal films have a strong odour. This does not indicate the presence of toxic materials, but you may wish to place the machine in a well ventilated area, however laminator should be kept in an area that has a stable temperature eg. Not near an open external door or window. Do not place a thermal laminator directly under air cooling outlets.

Ensure that the power outlet is readily accessible and installed near the laminating machine.

The machine should be in a well lit area, and you should have full access to the rear of the machine. Laminated items exiting the rear rollers should be able to fall directly to the floor or on to a work bench.

Cords from the machine should be placed so as not to be hazardous.

Note:- when not in use we recommend that the footswitch, if fitted, be placed on top of the machine to prevent accidental operation of the machine.

Pressure sensitive films work best in temperatures above 25 degrees celsius. Pressure sensitive laminates will develop a "silvering" effect, which will generally disappear after several hours exposure to temperatures above 25 degrees.

# THE THEORY - HOW A THERMAL LAMINATOR WORKS

Laminating film is made from polyester, and is coated with an adhesive with a high temperature resistance. This adhesive melts and becomes extremely sticky at temperatures of around 130 degrees Celsius. This film is drawn over two heated heater bars (1 heater bar and 1 heated roller if using a Centaur), through a set of rollers, then stretched flat by the rear pair of rollers. The item to be laminated is fed between the two layers of film as they enter the machine.

Under heat and pressure, the layers of film form a flexible air and watertight seal, thereby greatly increasing the lifespan of the laminated item, and making it less vulnerable to moisture, tearing, creasing and general damage.

Cross section of laminated item.

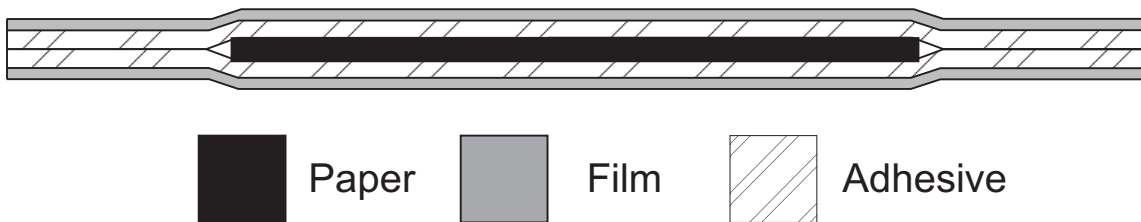

Main components of a roll fed thermal laminator.

- 1 Heater bars
- 2 Upper idler bar
- 3 Top film roll
- 4 Lower film roll
- 5 Lower idler bar
- 6 Front rollers
- 7 Rear rollers

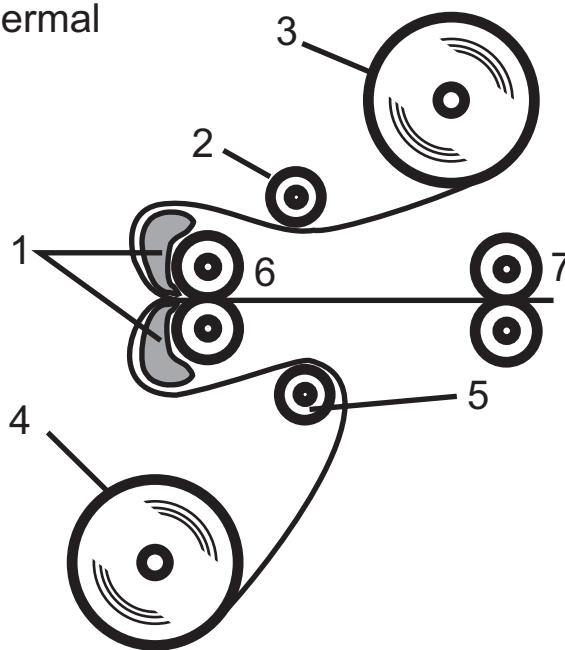

# THE THEORY - HOW PRESSURE SENSITIVE LAMINATION WORKS

Pressure Sensitive film is made from vinyl, polyester, polypropylene or something similar, and is coated with a strong adhesive. When pressed against material, this adhesive sticks strongly to the material.

Under pressure, the layers of film form a flexible air and watertight seal, thereby greatly increasing the lifespan of the coated product, and making it less vulnerable to moisture, tearing, creasing and general damage.

Some pressure sensitive films provide UV and graffiti protection,  
Cross section of pressure sensitive film.

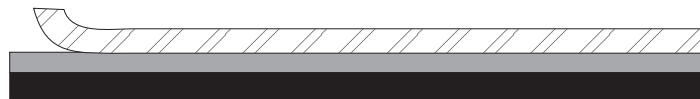

Main components of a pressure sensitive roll fed laminator.

1. Double sided adhesive
2. Backing paper rewind
3. Underlay roll
4. Upper idler bar
5. Lower idler bar

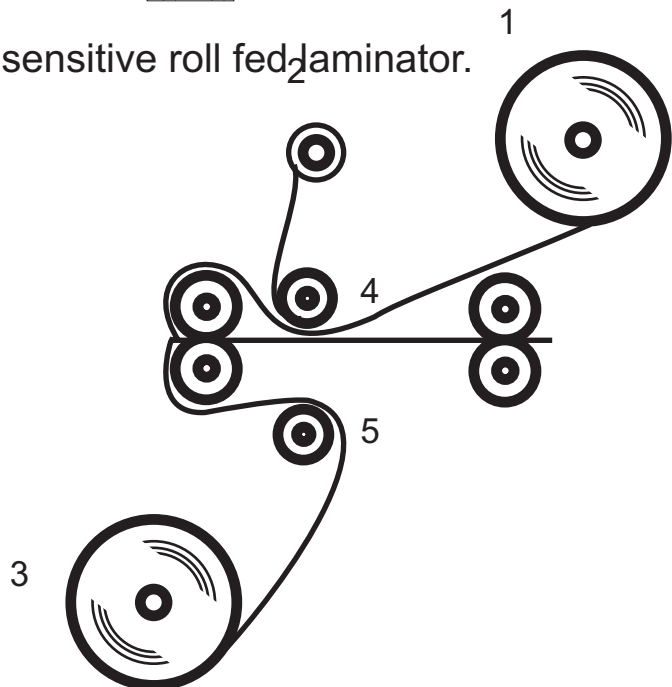

# UNPACKING/ASSEMBLING YOUR LAMINATOR

## Triseal Parts

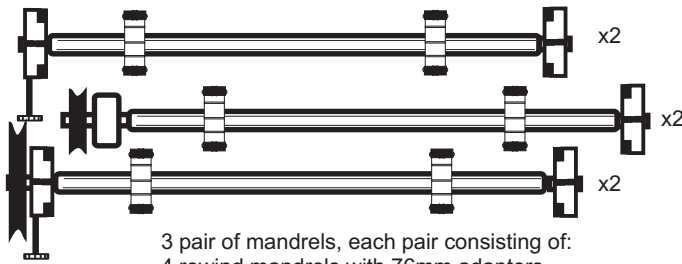

3 pair of mandrels, each pair consisting of:  
4 rewind mandrels with 76mm adapters  
2 standard mandrels with 58mm adapters

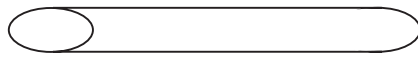

1 cardboard tube

Upper and lower Belt for rewind system

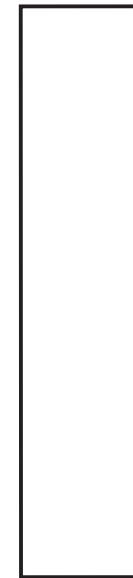

Load Plate

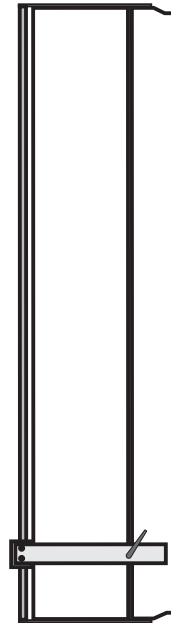

1 feed table with paper guide.

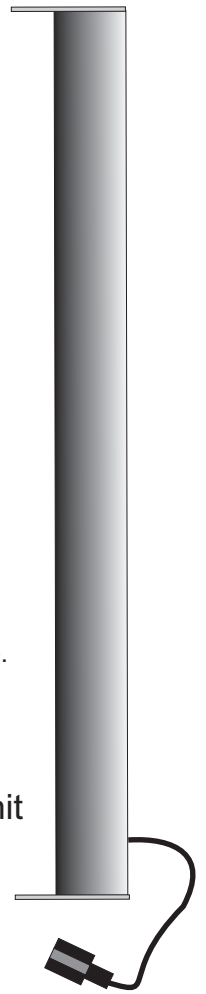

Removable top heater unit

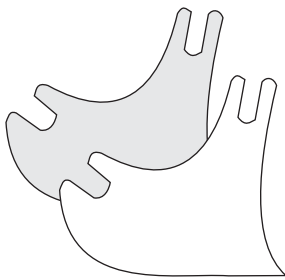

Upper Mandrel Bracket

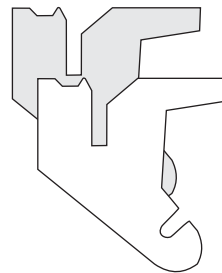

Lower Mandrel Bracket

## Assembly

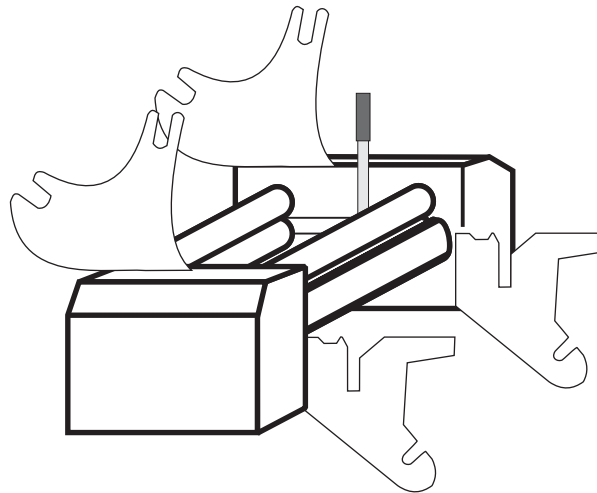

Bolt the upper mandrel brackets onto the machine as shown.

Bolt the lower mandrel brackets to the front of the machine, ensuring that the bent bracket goes to the left. Tighten all bolts with the allen key supplied.

If the laminator is going on to a stand, make sure that it is securely bolted to the stand with the bolts supplied.



## 4R Applikator Parts

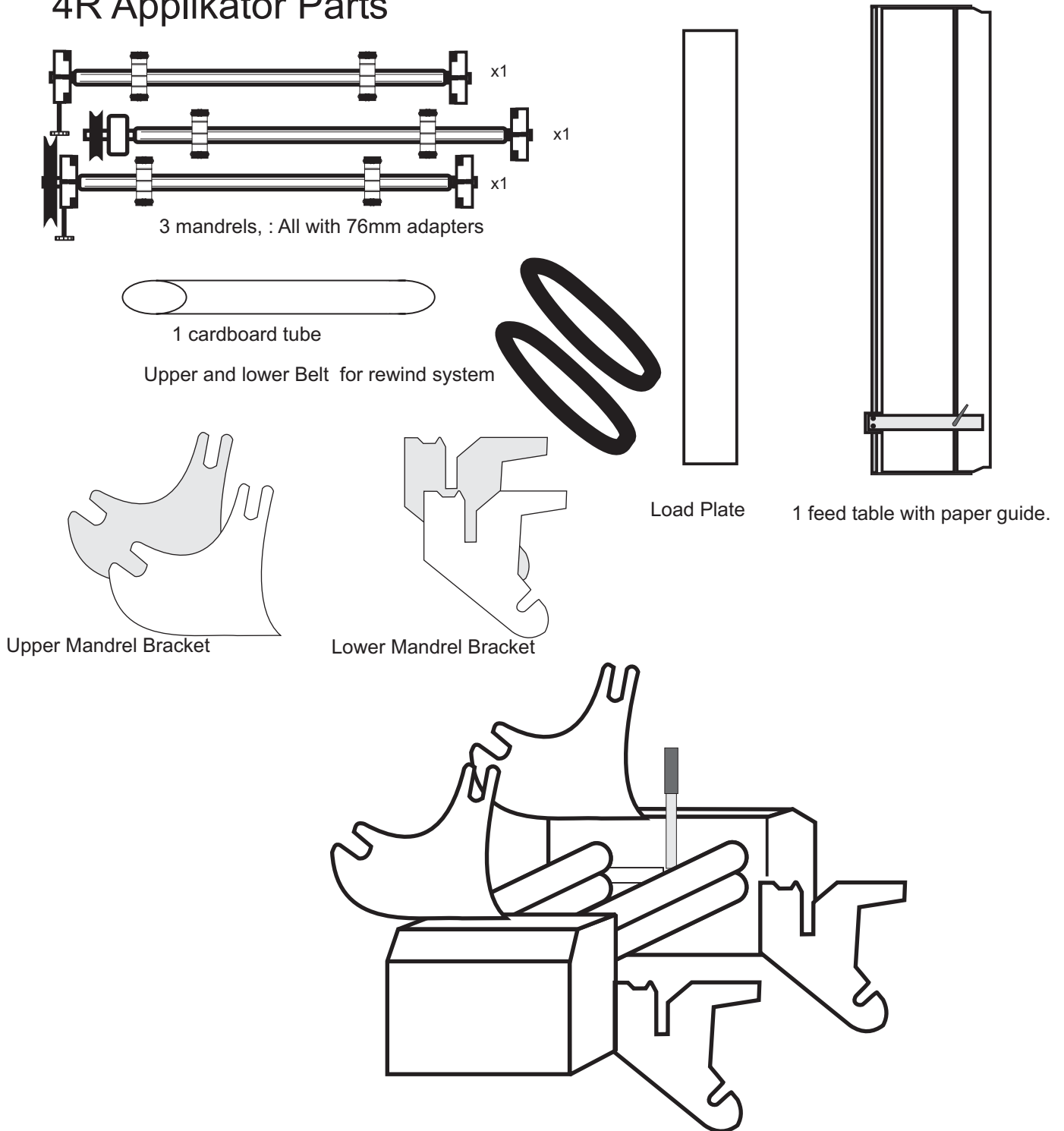

Bolt the upper mandrel brackets onto the machine as shown.

Bolt the lower mandrel brackets to the front of the machine, ensuring that the bent bracket goes to the left. Tighten all bolts with the allen key supplied.

If the laminator is going on to a stand, make sure that it is securely bolted to the stand with the bolts supplied.

# 2R Applikator Parts

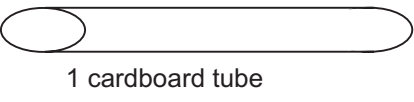
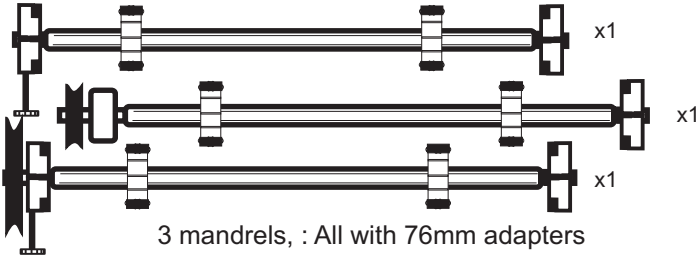

Upper and lower Belt for rewind system

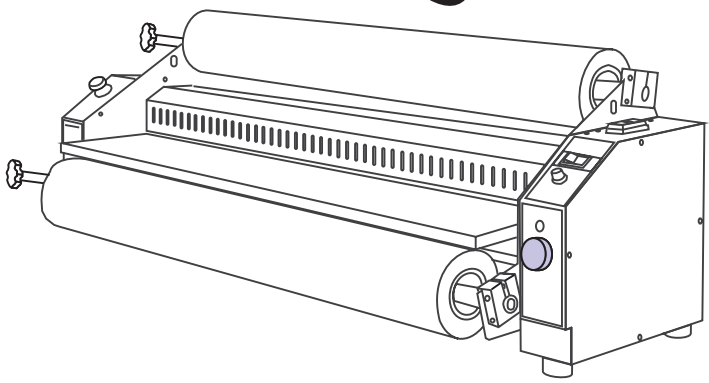

# Compact Parts

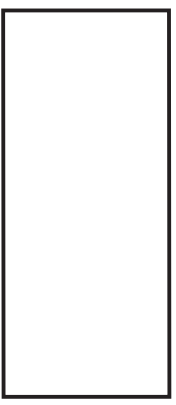
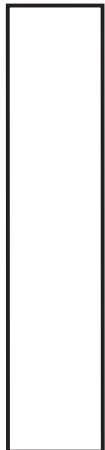
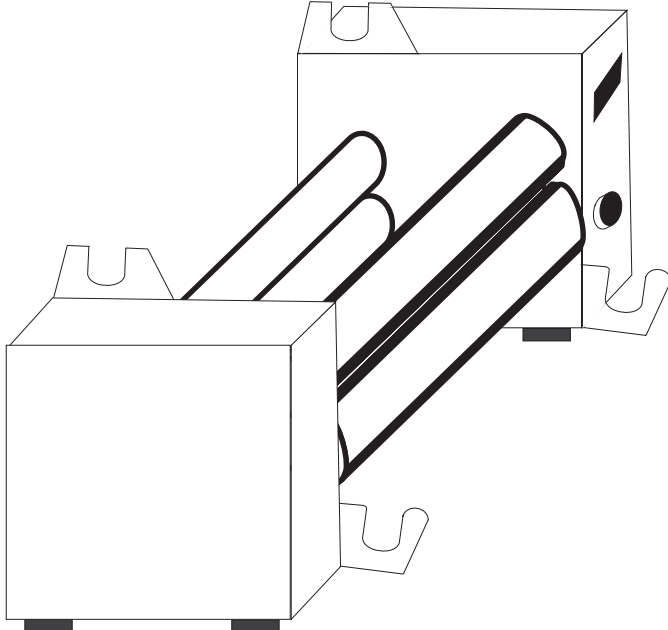
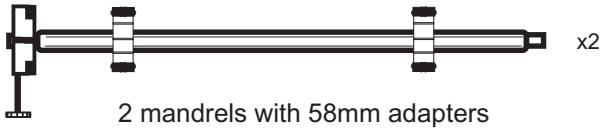

# Makrolam Parts

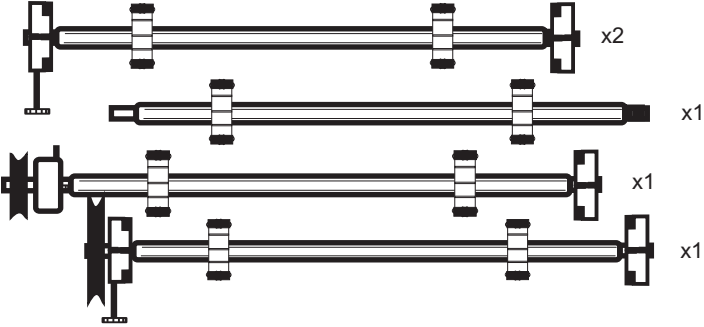

5 mandrels, : All with 76mm adapters



1 cardboard tube

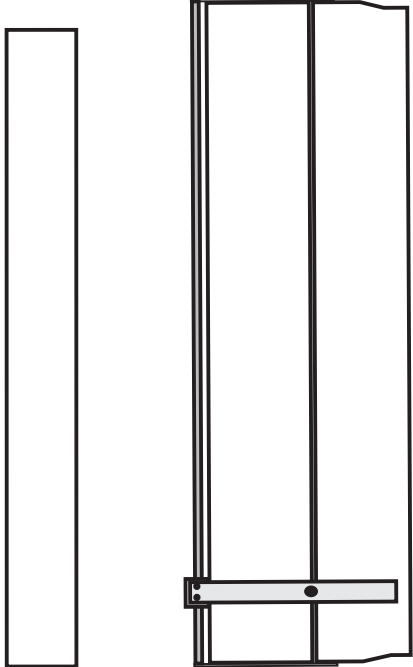
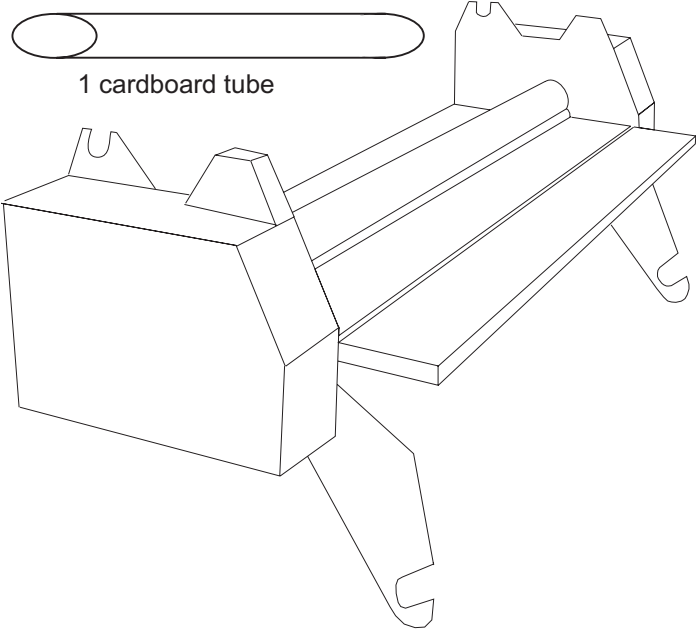

Load Plate

1 feed table.

# Emseal Parts

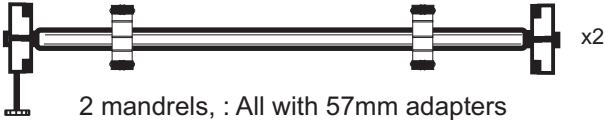
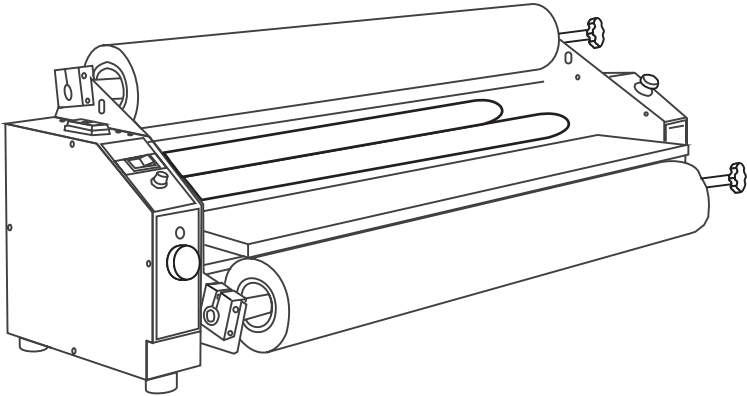

2 mandrels, : All with 57mm adapters



Load Plate



1 feed table.

# LOADING THERMAL FILM (Compact, Emseal and Triseal)

It is important to have the same type of film on the top and bottom, as different grades of film will adhere at different temperatures, and it is also important to use film that is the same width to avoid getting adhesive on the rollers.

Load the two rolls of film onto the mandrels, making sure the adhesive is facing in the correct direction (See diagram)



Upper roll of film.



Lower roll of film.

The lower idler bar is designed to move for ease of loading. When loading, the idler bar should be in the lower position. After the film has been pulled around the idler bar, you should move it upwards until it locks into the upper position.

The idler bar in the lower 'loading' position.

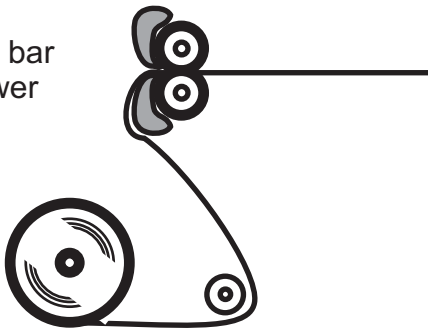

Lower idler bar is lifted up into operational position.

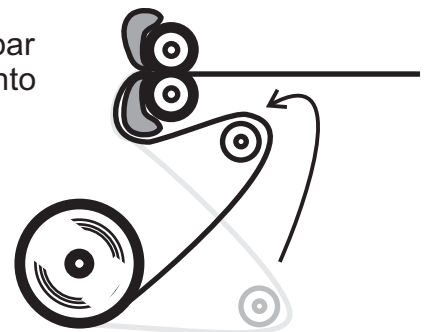

Load mandrels with the film into their respective mandrel brackets.

## LOADING THERMAL FILM (Compact, Emseal and Triseal) Continued

Draw the film from the top roll forward, under the idler bar, and allow it to hang down over the front of the heater bars. Now draw the film from the lower roll around behind the lower idler bar, then up and over the heater bars so it overlaps the film from the upper roll, as shown.

Now turn on the machine and allow it to reach the recommended temperature set, and set the motor to 'FORWARD'.

Take the load plate and press it against the film and into the front rollers. If the rollers are rotating in the correct direction, the load plate will be drawn into the machine, taking the film with it. When the load plate has exited the rear rollers, switch off the motor, and allow the laminator to reach the set temperature.

Heat up time should be around 10 minutes.

While waiting for the laminator to heat up, you may place the feed table onto the lower mandrel brackets.

If all has gone well, you should now be prepared to begin laminating.

As a suggestion, before committing valuable work, use a test piece such as a sheet of newspaper to check on adhesion. Run a sheet through the laminator, then cut it with a pair of scissors or a knife and check to see if it has adhered properly.

Cut a circle from the test sheet and check for flatness. If it curls upwards, release the tension on the top roller and repeat test.

Braking tension - On first loading new rolls of film into your laminator, substantial braking pressure may be required to get creasing out, dependant on the type of film. As soon as the creases in the film disappear, release the brake pressure to a point where the film may be rotated by hand with only slight resistance.

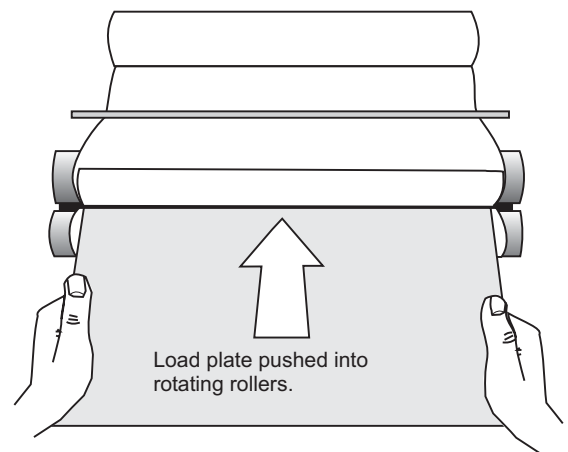
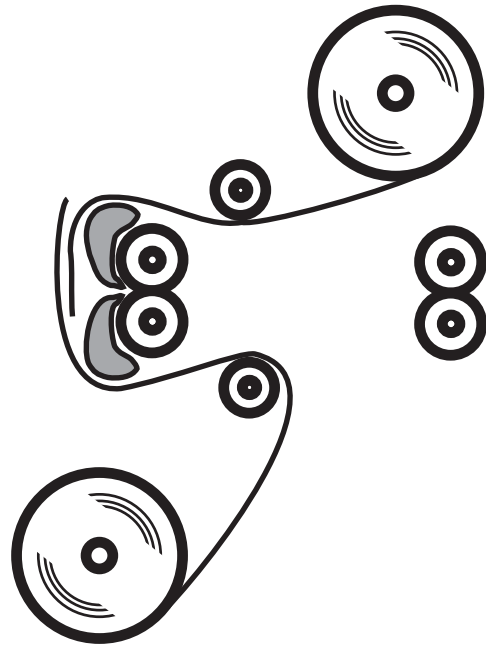

## LOADING PRESSURE SENSITIVE FILM (2R, 4R, Triseal and Makrolam)

There are several main ways of using the Laminator with cold film. These are single sided laminating, double sided laminating and board mounting.

### USE OF PAPER UNDERLAY

Underlay film is used to protect the rollers from the self adhesive film if you are laminating items which are narrower than the width of the film itself. This also prevents the self adhesive film from wrapping around the rear rollers if a gap is left between items.

What to use as underlay?

Use a very cheap plastic or paper. Remember that the underlay paper is discarded when used. Contact your supplier for a supply of underlay.

For single sided laminating, you will need the following.

1. Pressure sensitive film

2. Underlay paper

3. Cardboard core for rewind.

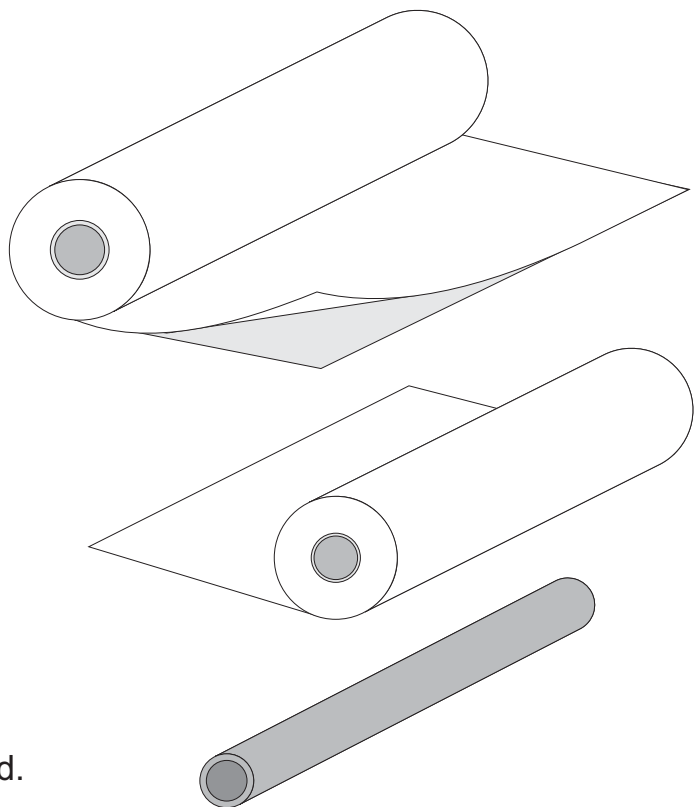

# LOADING PRESSURE SENSITIVE FILM (2R, 4R, Triseal and Makrolam)

## Loading the supply roll.

Before loading the film onto the mandrel, take a moment to look at the film and see from which side the film unrolls. Most self adhesive films will unwind from the underneath of the roll when loaded. Remember, when loaded the adhesive side must face away from the rollers.

The diagram below shows the direction from which to load the film onto the mandrel. Use the supply mandrel, which has the large pulley on the left hand side. Align the roll of film so that it is centered on the mandrel. The loaded mandrel may now be placed on the machine, on the rearmost mandrel brackets.

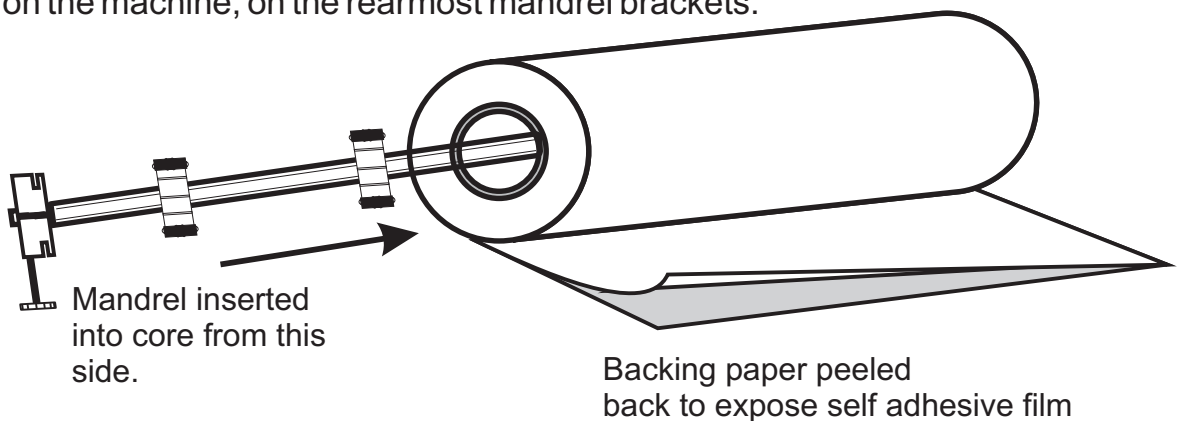

## Loading the underlay and rewind core

Load the empty cardboard core onto the rewind mandrel (which has a small pulley and no brake). Place the loaded rewind mandrel on the front upper mandrel bracket, and check that the rewind core is aligned with the rear film.

**Underlay Film** may now be loaded. Take the remaining mandrel (with a brake and no pulley) and load the film. Remove the feed table from the front of the machine and place the mandrel on the lower brackets. Check that the lower film is in alignment with the upper film. It is acceptable for this film to be wider than the self adhesive film.

## Loading the film into the machine

All mandrels should now be in their proper places. Check with the loading diagram to make sure of this.

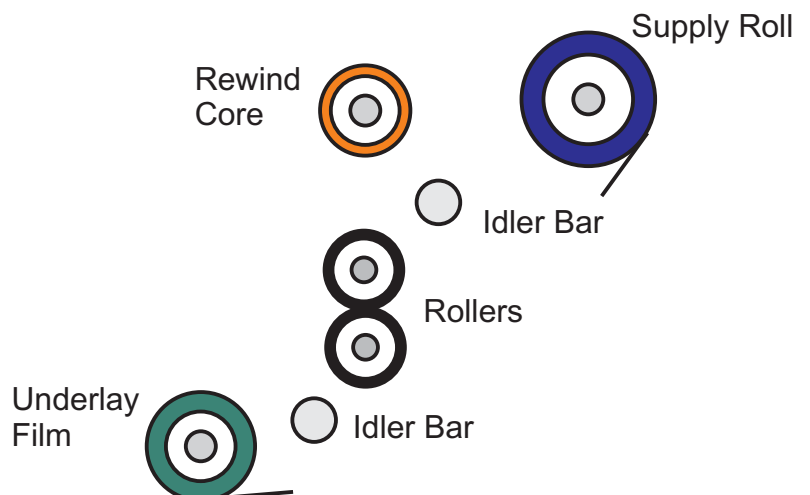

# LOADING PRESSURE SENSITIVE FILM (2R, 4R, Triseal and Makrolam)

## Step 1 : Self adhesive film and rewind.

Ensure the braking pressure on the pressure sensitive film and underlay is loose, by turning the film with your hand. It should turn easily on the roll. On initial load more tension may be needed for a short time, but this should be reduced as creases disappear from loaded film.

Pull the pressure sensitive film towards you from the supply roll, so that it passes under the idler bar and comes to rest on top of the roller. The idler bar helps to separate the film from the backing paper. The film path should follow the diagram below.

Peel backing paper from the film, lift it up to the empty core, and attach it to the core (see tips section for how to effectively attach this film. The exposed adhesive film should now be lying across the top roller, with the adhesive side facing you.

You can now attach the belt to the pulleys. The easiest method is this way:

- (1) Place belt around front small pulley
- (2) Stretch belt out to large pulley, resting it on the top.
- (3) By turning the large pulley counter clockwise while holding the belt onto it, the belt will roll into the groove.
- (4) Turn the large pulley clockwise to return the film to starting position.

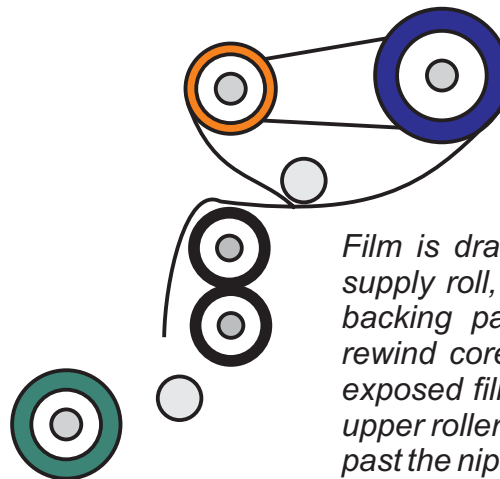

*Film is drawn forward from supply roll, separated, and backing paper attached to rewind core. Note that the exposed film lies across the upper roller and hangs down past the nip of the rollers.*

## Step 2 : Underlay Film

The underlay film can now be brought around the lower idler bar, and stuck to the adhesive surface of the film, as illustrated opposite.

Ensure that the film is aligned, this means that the underlay film meets the adhesive on both sides, so that no adhesive is directly in contact with the rollers. It is acceptable for the underlay film to be wider than the self adhesive film. The diagram below should indicate how the film meets at the edges.

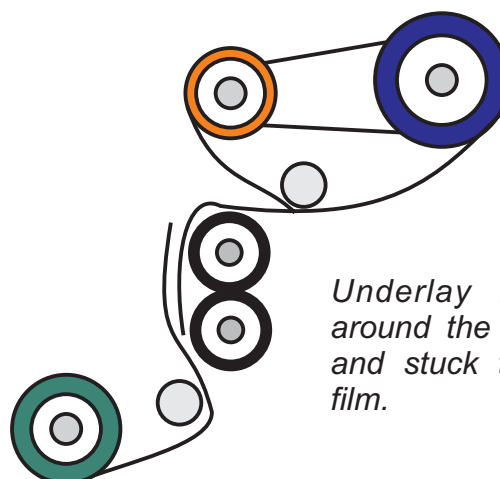

*Underlay film is drawn around the lower idler bar, and stuck to the exposed film.*



Indicates upper and lower film properly aligned.



# LOADING PRESSURE SENSITIVE FILM (2R, 4R, Triseal and Makrolam)

## Step 3: Feeding the film into the Applikator.

Set the machine to forward mode at a low speed, activate the machine and push the load plate supplied between the rollers until it is pulled through.

As illustrated, this will push both adhesive and underlay into the machine. Care must be taken to ensure that the underlay is not spooling through the machine while the upper roll stands still, as some underlay materials slip easily.

You may now increase the brake pressure of both the underlay and the adhesive film if necessary by turning the brake knobs clockwise one or two turns. This helps in loading the machine evenly.

Once the load plate has exited the machine, check to see that the film has loaded properly. Obviously, the film which has just exited the machine immediately after the load plate will show some wrinkling, but after a small amount of film has passed through the machine this should disappear. If you are satisfied with the appearance of the film, Congratulations! You are now ready to laminate! Continue on to the laminating section of this manual.

Wrinkles in the underlay are not uncommon, and can be tolerated as long as they have no result on the finished result. Remember that the underlay is removed from the finished item. The wider the film the more likely it is to wrinkle.

## Other Film loading techniques

### Laminating with a self adhesive backing

The Applikator 2R/4R allows you to simultaneously apply a coating and a double sided backing. This is ideal for creating stickers, self adhesive signs and labels, and for board mounting.

Loading for this technique is simple, replace the underlay film with a roll of double sided adhesive, but always remember...

**DO NOT PASS DOUBLE SIDED ADHESIVE UNDER IDLER BAR, AN OPTIONAL PLASMA COATED BAR IS AVAILABLE FOR THIS..**

It is important that the double sided adhesive is the same width as the pressure sensitive film. A film which is too wide will leave deposits on the rollers. Once the items have been laminated you can trim them to their edges, and peel off the backing paper to reveal the adhesive surface.

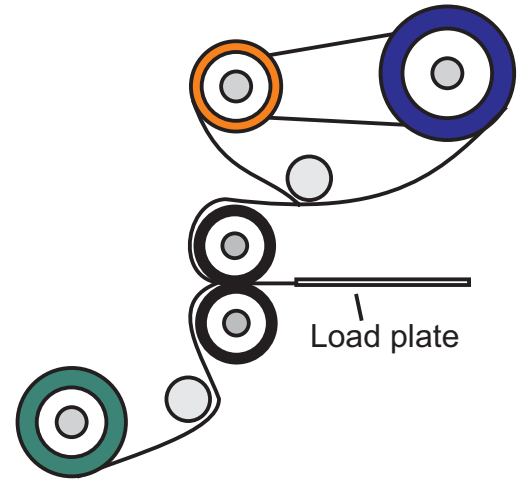

*The load plate pushes the film into the rollers and carries it through.*

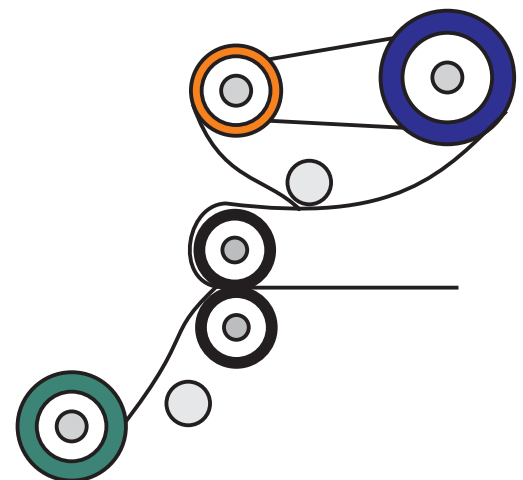

*The roll of underlay is replaced with a roll of double sided adhesive. Note that adhesive bypasses lower idler bar.*

# OTHER FILM LOADING TECHNIQUES

## Double Sided Lamination

With the addition of the machine trolley and rewind kit, the Applikator 2R/4R is capable of double sided laminating, by allowing two rolls of pressure sensitive film to be stripped of backing paper simultaneously.

The advantage of double sided laminating is that it provides complete protection of an item by sealing completely around it. This method can also be used to laminate two items at once, fed into the machine back to back.

The loading process is a little more complex than single sided laminating, but should present few problems. As the film is on both sides no underlay will be needed.

This process requires extra mandrels, you will need in total:

- 2 x supply rolls,
- 2 x rewind mandrels
- 2 x rewind belts

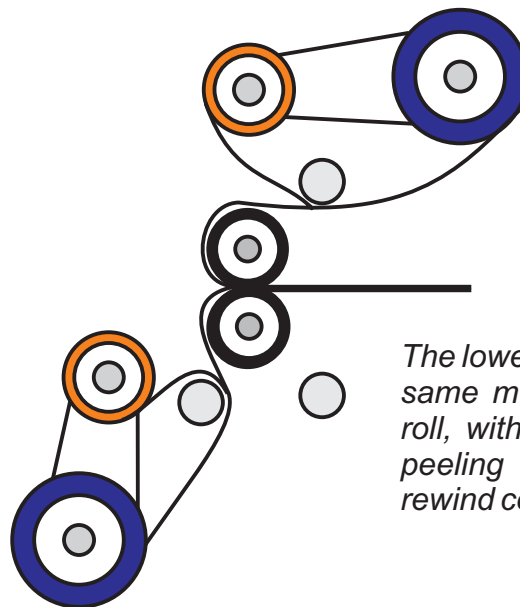

*The lower roll is loaded in the same method as the upper roll, with the backing paper peeling off onto the lower rewind core.*

In this method the lower loading reflects the upper loading, with the mandrel normally used for underlay film now being used for rewind of backing paper.

Once the lower backing paper has been attached to the lower rewind core, you may stick the lower film to the exposed upper film, and complete loading the film.

For the full benefits of double sided lamination, you must remember to leave a border of film around the laminated item to ensure an airtight seal.

It is also possible to laminate two items together using this method by feeding both items into the machine back to back. Once the film has been cut from the edges, you will have two single sided laminations.

# 2R ROLLER OPENING SYSTEM

The Applikator 2R opening roller system consists of two separately operated levers, one on each end of the upper roller. This system is designed for use when laminating very thick items, and for when the machine will not be used for long periods of time such as storage or shipping.

**IMPORTANT NOTICE :** It is vital that you **DO NOT** grease, oil or lubricate the lift up mechanisms. The lift up mechanism is not subjected to heat or friction, and lubrication will cause difficulties with this mechanism, as it not designed to require lubrication.

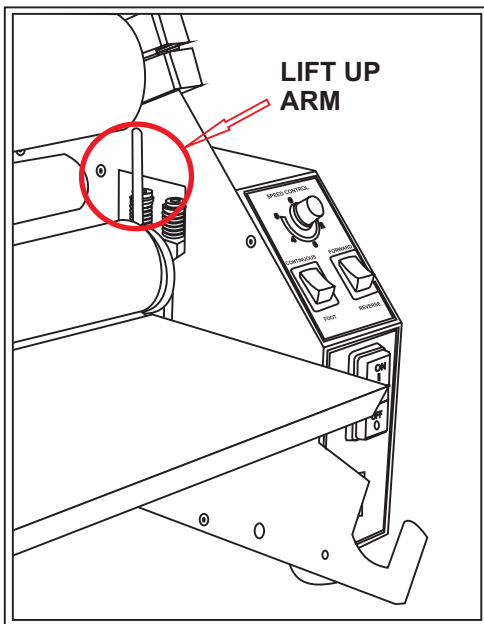

**Fig.1** Rollers in closed position, note position of lift up lever.

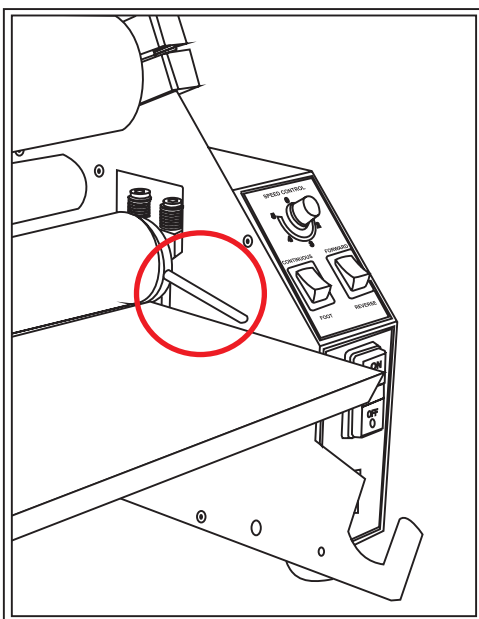

**Fig.2** Rollers closed, lever in downwards position.

## Rollers Closed

(Standard usage position)

This should be how the roller lift up system appears when the machine is in general use. With the lift up arms pointing upwards, the rollers are closed and ready for usage. The lift up arm can even rest against the upper idler bar.

It is important to make sure that the levers of both the left and right hand side of the roller lift up system are in the same position in order to keep the rollers parallel.

To close rollers from the open position, lift the levers upwards until they feel loose and move easily. Once you stop moving them, they will settle back into their rest positions.

## Rollers Open

(Thick item lamination, shipping, storage.)

The roller open position will appear as shown in figure 2. Both left and right levers will be on a downward angle, and a gap of even distance along the length of the rollers will be visible.

To use, push both left and right lift up levers down as far as they will go. They may move upwards slightly, but will remain at a downwards angle, leaving a gap between the rollers.



This allows the introduction of a thick item - up to 5mm soft substrate such as foam core board or core flute, or 3mm hard substrates such as MDF into the rollers. Once the item has been pulled between the rollers, move the roller lift up levers to their uppermost, closed roller position (see fig. 1) to apply pressure onto the item. Once the thick item has passed through the machine, the rollers will close behind it.

# TRISEAL/4R ROLLER OPENING SYSTEM

Opening rollers allow you to pass thick card or soft substrate such as foam core board or core flute up to 13mm thick through the laminator (Hard substrates such as MDF would need to be laminated on a Makrolam). This is used when applying self adhesive film to thick items, or for board mounting.

Depending upon spring tension, the rollers can sometimes be difficult to move. To open the bars properly, pull the handle on the right hand side of the machine towards you and down..

There are three steps in the opening rollers, 0-4mm, 4-8mm, 8-13mm.

 0-4mm       4-8mm       8-13mm

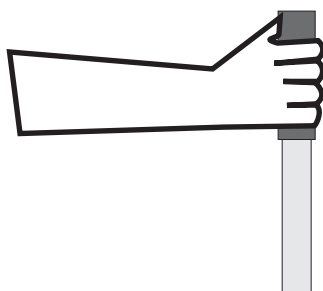
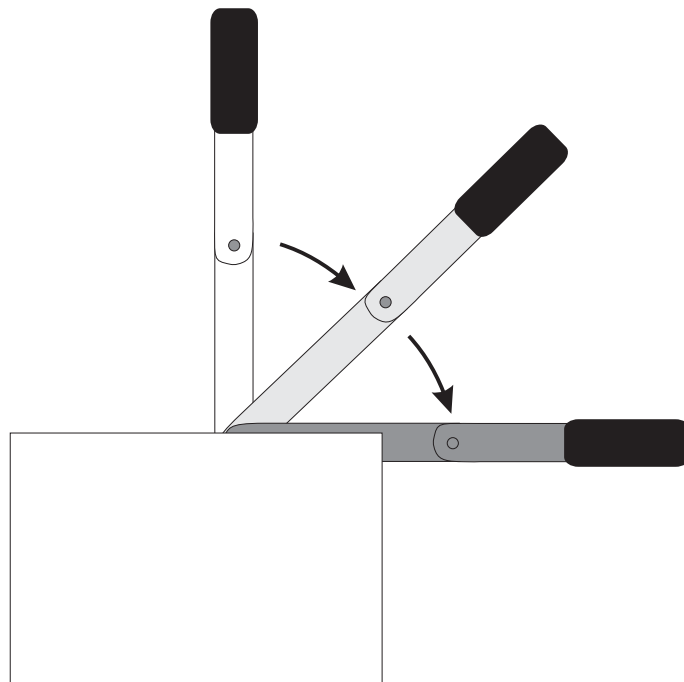

# TRISEAL - ADDING /REMOVING TOP HEATER BAR

## HEATER BAR REMOVAL

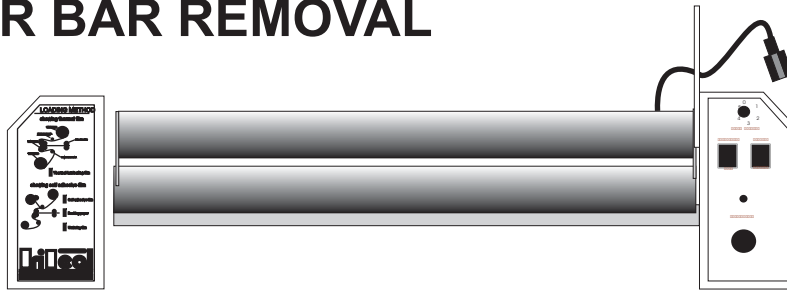

Switch the mains to 'OFF'. If the machine is hot from use you may want to let it cool down before removing the heater bar, or use gloves or cloths to protect your hands. Unplug the heater bar from the machine.

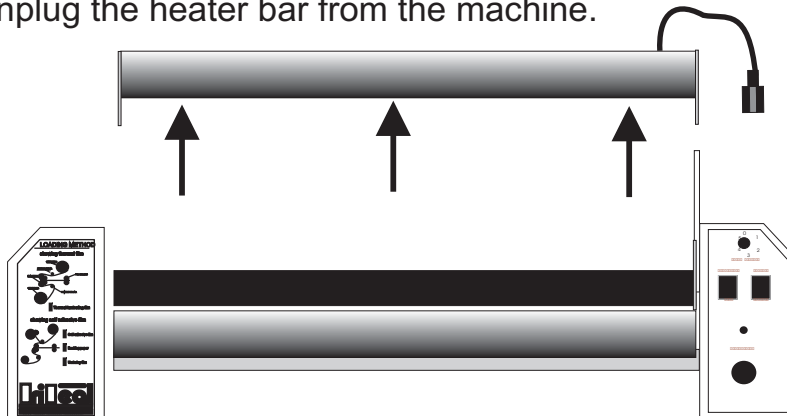

Lift the heater bar vertically until the brackets on the sides have cleared their mounts. When not in use the heater bar should be stored in a dry place, where it cannot fall or be knocked. Hard blows to the heater bar can cause damage to the teflon coating, or break the internal components.

## REPLACING THE HEATER BAR

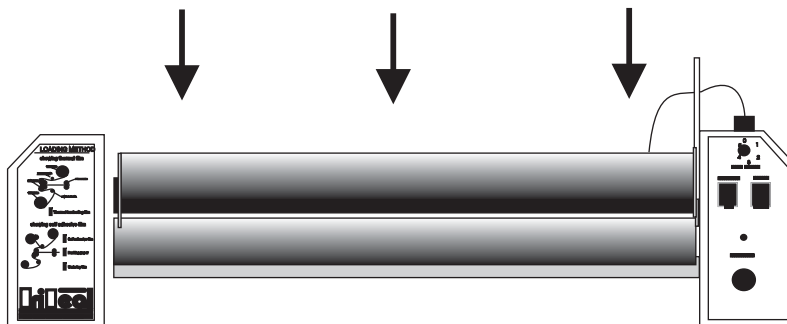

Carefully place the bar back in its original position, with the Teflon coating facing outwards and the plug on the right. The metal brackets should fit firmly over the square black bearing blocks, and the whole assembly should have very little movement. Ensure that the machine is switched off and cool, and plug the heater bar in. It is important that the lower heater bar is cold before heating the machine after replacing the heater bar.

When using cold film, the heater bar can be used as a heat assist at no more than 45 degrees centigrade. Check with your film supplier for film suitability prior to doing this.

# FEEDING ITEMS INTO YOUR LAMINATOR

The initial feeding of an item into the machine is the most important part of the lamination. If an item enters the machine on an angle, or with wrinkles in the leading edge, the entire item may be ruined. Fortunately, pressure sensitive films are quite forgiving, and achieving proper results should present little problems.

Some items are easier to laminate than others, generally smaller and more rigid items are the easiest to laminate. A very large, thin item may seem daunting, but should provide few problems if you understand the correct methods for item feeding.

With instruction and a little practice it is easy to feed items into the machine properly 100% of the time.

## Feeding single items.

This is the most common type of lamination, in which single items are fed into the machine one after the other. This example covers most of the technique involved in proper laminating.

Switch the machine to forward mode and select a low speed. Do not start the rollers turning yet.

Lay the item flat on the feed table and slightly stretch the leading edge with your fingers. Move the item into the rollers until it is touching the film. If you know that the leading edge of the item is straight you can align this visually, or by inserting the item far enough into the rollers that it stops (this should be done by gently sliding the item forwards).

Ensuring the leading edge is flat is very important, as a small wrinkle at this point may continue through an entire poster.

Once you are satisfied that the item is straight and flat, Let the print go through the machine. It is recommended that you stretch the item slightly back and sideways to make sure that it does not wrinkle as it enters the machine. Do not push the item into the machine, as this will wrinkle the leading edge, instead allow the rollers to grip and then pull the item in.

Once the item has passed through the rollers you may stop the laminator and prepare the next item for laminating in the same method as above. If you are only laminating one item and need it removed from the machine, keep the motor running until it has passed through the rollers.

Some films leave a mark if the rollers stop, it is advisable to only stop the rollers when an item has exited the machine.

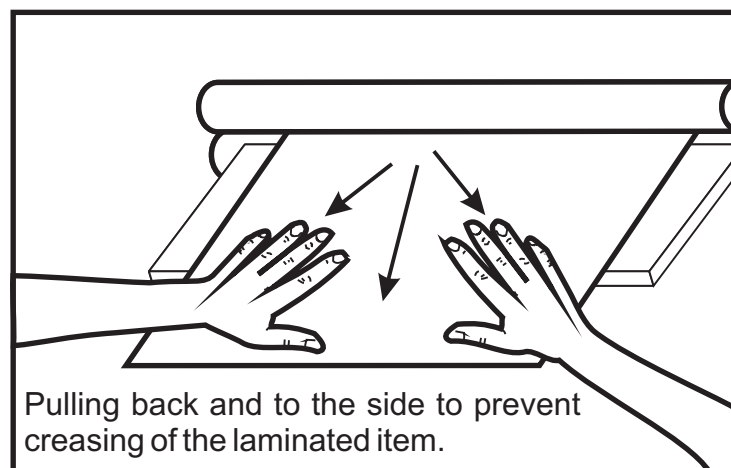

# FEEDING ITEMS INTO YOUR LAMINATOR (CONTINUED)

## Feeding multiple items.

If you are laminating items with a combined width narrower than that of the film, you can laminate them side by side to prevent wasting large amounts of film, or necessitating having film cut to special sizes.

Following the instructions for feeding single items to ensure straightness, feed the items into the machine next to each other with a small gap in between them. It is very important to ensure that the items are straight as multiple items may overlap one another if improperly fed into the machine. For this process you may wish to have an assistant.

You can feed as many small items into the machine next to one another as you are capable of handling, however all items for side by side laminating must be the same thickness.

Note: Poor quality of lamination in between the items is due to the roller being lifted slightly, however after trimming this effect is not noticeable. The thicker the items you laminate the more you will notice this.

## Feeding very long items.

*Very long items, regardless of width, can be the hardest to laminate properly. Minor ripples at the beginning of a lamination can turn into major creases through an item, causing costly waste. Irregular pressure in the feeding of an item can cause all manner of problems, and holding the item back with the hands is sometimes not sufficient. However, with proper technique, the prospect of laminating a long item should not be a daunting task.*

The following method will show you how to easily prevent these problems from occurring.

Take an empty cardboard core (the diameter of the core is irrelevant, but the core must be rigid). Wind the item to be laminated onto the core so that the image is wound facing the inside of the roll. Some images, particularly inkjet prints may need to be dried properly before being wound onto a roll to prevent damage. Lay the roll on the feed table, allowing the leading edge of the item to feed into the roller. The less of the item you allow to spool from the roll the easier it will be to feed the item straight.

Once the item is fed into the machine, start the motor, and by gripping either end of the core you will find it easy to exert a constant, even back pressure as the item is unwound from the core into the machine.

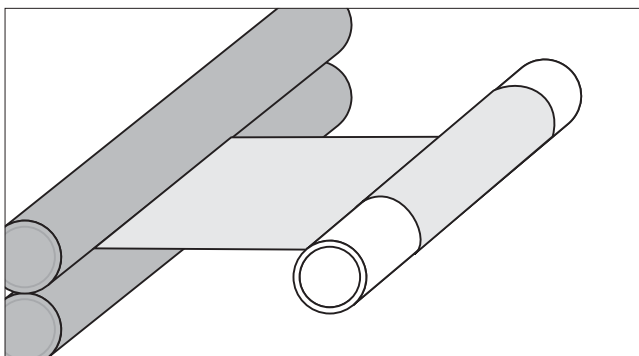

*With a long item wound onto a cardboard core, it becomes simple to ensure even back pressure, and proper lamination.*



# BOARD MOUNTING (2R, Triseal and Makrolam only)

The most important part of board mounting is to ensure that the substrate you are using is clean and free from jagged edges and splinters. This is one of the most common and easiest ways to damage the rollers of your laminator.

Board mounting (also known as dry mounting) is the laying down of an item onto a rigid substrate, giving a smooth, even and rigid finish to the item.

## Board mounting methods

Firstly, choose one of the below methods for your block mounting.

### Method A - Adhesive boards

In this method the board itself is coated with a layer of double sided adhesive. The advantage this method has is that many boards can be coated with adhesive and then stored for later use. Note: Do not store coated boards for a long periods of time.

Load the machine with a double sided adhesive and underlay film.

Note: Some double sided adhesives may cause the board to buckle after long term storage.

Once loaded, feed the boards into the machine. You may need someone to assist in removing the boards from the rear of the machine while you control the motor.

### Method B - Adhesive item

In this method the back of the item is coated with the double sided adhesive. The advantage of this method is that you can coat the items with double sided adhesive and pressure sensitive film at the same time. Simply load the machine as described for self adhesive backing, and laminate items as needed.

## Mounting the item

Before beginning the mounting you must remove the film from the rollers. Simply cut the film (taking care not to damage the rollers) and wind it back onto it's rolls. You do not need to remove the rolls from the mandrels.

Follow the steps below to prepare for block mounting.

### (1) Cut the board to size.

The correct size for the board is approximately 5mm wider on each side than the item to be mounted. This allows for a small margin of error when mounting. Light boards such as cardboard, foam core and plastic may be cut with a knife and steel ruler. It is recommended that you lay the item on top of the board and mark the edges with a pencil before cutting.

### (2) Attach the item to the board.

**Adhesive board method:** Peel the adhesive back from the leading edge of the board, to reveal about 25mm (1 inch) of adhesive.



## MOUNTING THE ITEM (CONTINUED)

**Adhesive item method:** *Peel the adhesive back from the leading edge of the item to reveal about 25mm (1 inch) of adhesive.*

Ensure the item is straight, and press the edge of the item firmly against the exposed adhesive. The item should remain aligned with the 5mm gap on either side.

Push the item into the rollers, so that the joined edge is at the front with the item on top of the board.

Reach under the item and grasp the release paper of the double sided adhesive. When you are ready to laminate, activate the machine at a slow speed, and pull back the release paper so that it is not pulled through the rollers. At the same time keep a back pressure on the item. you may need another person to help, or you can use one hand for each task.

If the release paper is caught between the rollers, simply stop and reverse the machine until it is free and you can resume stripping it from under the item.

Once the item has left the machine it is ready to be trimmed to the edges so that the exposed board is removed.

# TIPS AND TRICKS

## Attaching release paper to rewind core

When loading the rewind mandrel, it can sometimes be very difficult to adhere the film to the cardboard core, as the release paper is designed to prevent adhesion. By using a strong stapler gun it is easy to staple the rewind paper to the core.

It is also possible to cut off the first 50mm (2") of film (not release paper), and using this as tape attaching the film to the core.

## Economising with film

There are many ways to economise with the laminating film. Following are a couple of the most common.

- (1) Minimise the gap between items being laminated (not always possible). You may even overlap the beginning and end of following items if there is an area on the items which will be removed after lamination.
- (2) Use a film which is the same width as the items being laminated (this does require accurate item feeding).

# TROUBLESHOOTING

## There are wrinkles in the film

Wrinkles in the film have several different causes. In the following section we shall show the cause and cure of this problem. Please remember that wrinkles in an underlay film are only a problem if they affect the finished result.

### Horizontal wrinkles in film (1)

These wrinkles are seen most often in the wider laminators, and are due to a lack of roller pressure, causing the rollers to pull too much in the middle.

#### Solution:

First, try increasing the braking pressure on the supply and underlay mandrels by a small amount. If this does not seem to help, increase the roller pressure a little and try again. Roller pressure can be adjusted with the supplied allen key. Adjustments are made at both ends of each roller by turning the bolts either forward or backwards. You should not over tighten the brake. The underlay paper should firm, but still able to be turned with one

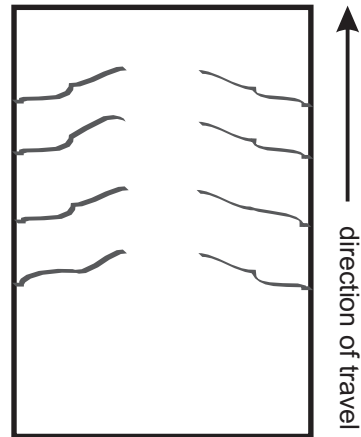

### Horizontal wrinkles in film (2)

Horizontal wrinkles in laminate (2)

These wrinkles are seen most often in the wider laminators, and are due to excessive pressure on the sides of the rollers.

#### Solution:

Decrease the roller pressure (see maintenance section)

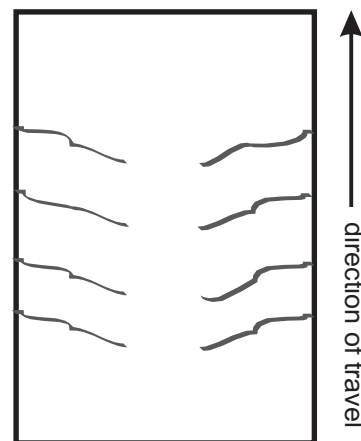

### Horizontal wrinkles in film (3)

Wrinkles at end of item

This problem occurs mainly when an item which has been rolled, or is curled, has not been held flat as the end portion enters the rollers. This causes the item to curl up into the film as it enters the rollers.

#### Solution:

Hold the item down firmly as the last section enters the rollers, or roll the item in the opposite direction to reduce curl.

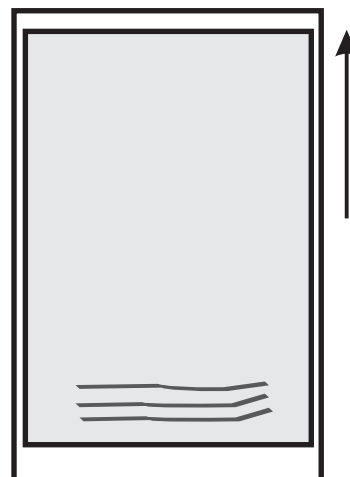

# TROUBLESHOOTING (CONTINUED)

## Vertical wrinkles in film (1)

A crease travelling along the item.

The crease may start at any point in the item and travel along to the end. It only affects the item being laminated.

This problem is caused by an item being incorrectly fed into the machine, or not held flat as it passes through the rollers. Refer to the section on feeding items into the machine.

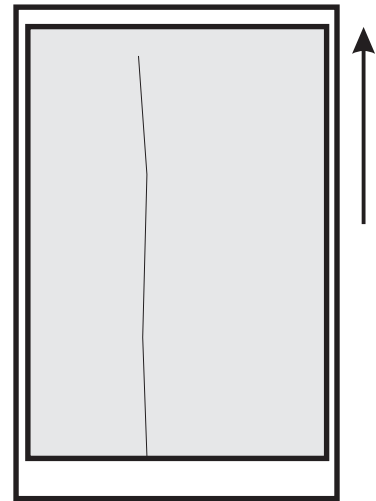

## Vertical wrinkles in film (2)

A crease travelling through the film.

A crease running through the laminate when there is nothing being laminated.

Not a very common problem. This may be caused by the film being incorrectly loaded. Check if the film is creasing as it passes over the roller, if so you may wish to reload the cold film by cutting it and adhering it to the film on the roller.

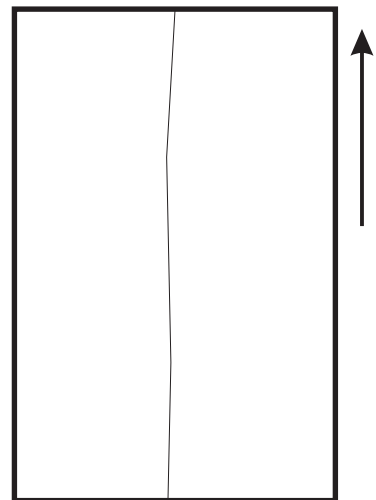

## There are bubbles in the laminated item

There are several different causes of bubbles in the finished item.

Type of bubbling: A repeating mark.

If the mark is roughly the same size and shape, and is repeated at very even intervals, the cause may be a damaged roller or a problem with the film. Look carefully at the rollers to see if there is any damage to them, even a small piece of rubber missing or off cut of film can cause a mark.

Type of bubbling: Large areas with small, joined together bubbles.  
This may be caused by one of several things:

### **(1) A rough or textured surface on the item being laminated**

Check the surface of the item to make sure that it is fairly smooth and flat.

### **(2) Blisters/bubbles**

Blisters/bubbles in thermal machines are commonly caused by excessive temperature or a high moisture content in items being laminated. High humidity can also be a frequent cause.

## **TROUBLESHOOTING (CONTINUED)**

### **There are bubbles in the laminated item (continued)**

#### **(2) *Low adhesion on the film being used***

If this problem occurs after changing to a new roll of film, check if the adhesive is as strong as on the last roll of film. If using cold film, check room temperature as colder conditions affect how cold film laminates.

#### **(3) *Lack of roller pressure (uncommon)***

If you have checked the above causes you may wish to check that there is sufficient roller pressure on the front rollers.

**Type of bubbling:** Occasional spots, small in size in random positions.

The major cause of tiny bubbles in lamination (mostly noticeable in areas dark in colour) are specks of dust stuck to the item prior to laminating. To avoid this try laminating in a dust free environment, or alternatively blowing or wiping the dust from the surface as the item is being laminated. Silvering on cold film is due to a cold ambient temperature. The silvering affect will generally disappear after approx. 24 hours.

### **The rewind belt has broken**

It is very uncommon for the rewind belt to break, but if they are placed under a lot of stress they may break at the point where they were joined. To repair this, simply cut clean ends on the rubber and use a small amount of Loctite 406 on the two ends and hold them firmly together for a minute, or until they are secure. Allow five minutes to dry, and then use.

### **The Laminator is making an unusual noise**

When operational the laminator should make a small amount of noise, but if this noise becomes loud or obtrusive there may be a problem.

**Noise :** A repeated banging noise, particularly when brake pressure is applied.

This noise is the chain skipping on the gear, and can be caused by excessive braking force over a prolonged time.

**Noise :** A squealing/shuddering noise may be caused by break pressure being too tight, Possibly too much heat or there may be a fault with the film.

### **Static Electricity Sparks**

It is not unknown for a small electric spark to jump between two metal parts while the machine is running. This is static electricity, caused by friction between the plastic film and the machine, and is not a cause for concern. This phenomenon can be seen more often in dry and warm climates. If this is occurring you may also on rare occasions receive a tiny shock, the same as touching metal after walking over some carpets.

This effect will be fairly minor, if you feel something is wrong with the machine electrically, please cease using the machine, and contact your supplier or a technician.

### **Major mechanical or electrical malfunction.**

In the unlikely event of a major mechanical or electrical malfunction, contact your supplier or a qualified electrician or technician.

# TROUBLESHOOTING (CONTINUED)

## Can't get wrinkles out of underlay paper

If the paper is wrinkling to the inside of the rollers, there is not enough pressure on the outside of the rollers. Put more pressure on the rollers by putting half turns on each screw on either side of the laminator.

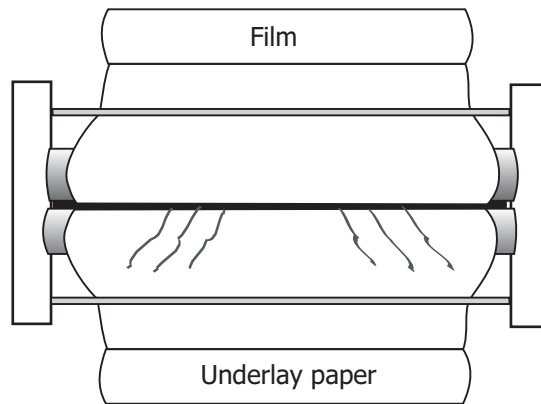

If the paper is wrinkling to the outside, there is too much pressure on the outside of the rollers. Release pressure by taking half turns off each screw on either side of the laminator.

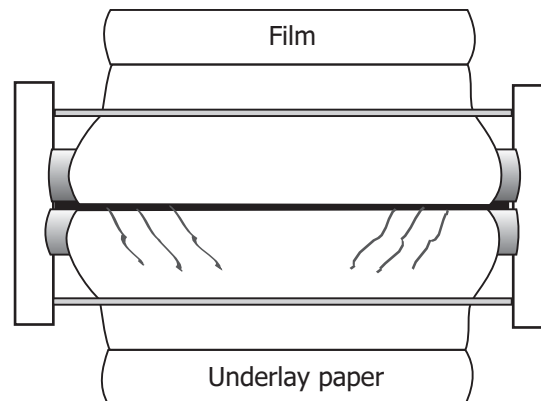

# TROUBLESHOOTING (CONTINUED)

## The machine won't run.

If you cannot make the machine run, please check that;

- The power plug is firmly in its socket
- There is power to the socket
- The circuit breaker is illuminated
- The 'On' switch has been depressed and is lit up
- The emergency stop has been released
- The speed control is turned on
- The control mode (foot / continuous) is correct.

If you have checked all these and still cannot make the laminator run, you may wish to contact your supplier or technician.

## Adjusting Roller Pressure

Note: Roller pressure is preset at the factory and should not need to be adjusted, however in some cases it is possible for different films to use different settings, and adjustment may be needed.

